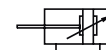

»SE« series

10.DMD.32025–10.DMD.125900

Symbol

Product features

These cylinders are ideal for a wide range of applications owing to their robust design and excellent value for money.

The standard type is double-acting with a magnetic piston as well as integrated adjustable cushioning.

The magnetic switches are mounted in T-slots on three sides of the body.

Specifications / Technical data

Piston-Ø [mm]	32	40	50	63	80	100	125
Acting type	Double acting						
Fluid	Filtered, unlubricated or lubricated compressed air (to be filtered by 40 µm filter element). If lubrication is used, it must be continuous.						
Working pressure	1–10 bar (0.1 to 1.0 MPa; 14 to 145 psi)						
Proof pressure	15 bar (1.5 MPa; 215 psi)						
Temperature range	-20 to 70 °C						
Speed range	30–800 mm/s						30–500 mm/s
Cushion type	Adjustable						
Cushion stroke	27 mm		30 mm		36 mm		40 mm
Port size	1/8"	1/4"		3/8"		1/2"	

Stroke

Piston-Ø	Standard stroke	Max. stroke	Available stroke ¹⁾
32	25 / 50 / 75 / 80 / 100 / 125 / 150 / 160 / 175 / 200 / 250 / 300 / 350 / 400 / 450 / 500	500	1800
40	25 / 50 / 75 / 80 / 100 / 125 / 150 / 160 / 175 / 200 / 250 / 300 / 350 / 400 / 450 / 500 / 600 / 700 / 800	800	1800
50	25 / 50 / 75 / 80 / 100 / 125 / 150 / 160 / 175 / 200 / 250 / 300 / 350 / 400 / 450 / 500 / 600 / 700 / 800 / 900 / 1000	1000	1800
63		1000	1800
80		1000	1800
100	25 / 50 / 75 / 80 / 100 / 125 / 150 / 160 / 175 / 200 / 250 / 300 / 350 / 400 / 450 / 500 / 600 / 700 / 800 / 900	900	1800
125		900	1800

(Values in mm)

¹⁾ on request

Ordering information

Art. No.	Piston-Ø	Stroke	Connection	Piston rod-Ø	Piston rod male thread
10.DMD.32025–32500	32	25–500	G 1/8	12	M10x1.25
10.DMD.40025–40800	40	25–800	G 1/4	16	M12x1.25
10.DMD.50025–501000	50	25–1000	G 1/4	20	M16x1.5
10.DMD.63025–631000	63	25–1000	G 3/8	20	M16x1.5
10.DMD.80025–801000	80	25–1000	G 3/8	25	M20x1.5
10.DMD.100025–100900	100	25–900 ¹⁾	G 1/2	25	M20x1.5
10.DMD.125025–125900	125	25–900 ¹⁾	G 1/2	32	M27x2

(Values in mm)

¹⁾ Stroke 1000 available on request

»SE« series

10.DMD.32025–10.DMD.125900

Dimensions

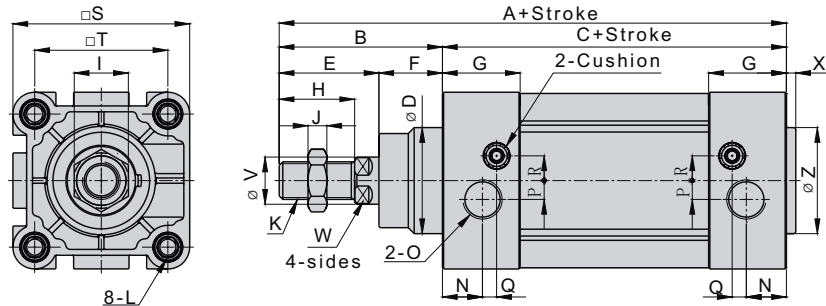

Piston-Ø	A	B	C	D	E	F	G	H	I	J	K	L	N	O	P	Q	R	S	T	V	W	X	Z
32	142	48	94	30	29	19	27.5	22	17	6	M10×1.25	M6	13.5	1/8"	5.8	6	6.3	46.5	32.5	12	10	3	30
40	159	54	105	35	33	21	32	24	17	7	M12×1.25	M6	17.5	1/4"	6	5.5	9	54	38	16	13	3.5	35
50	175	69	106	40	42	27	31	32	23	8	M16×1.5	M8	14	1/4"	8	5	10.5	64	46.5	20	17	3.5	40
63	190	69	121	45	42	27	33	32	23	8	M16×1.5	M8	17	3/8"	8	6	10.5	75	56.5	20	17	4	45
80	214	86	128	45	53	33	33	40	26	10	M20×1.5	M10	16.5	3/8"	8	8.5	12.5	93	72	25	22	4	45
100	229	91	138	55	55	36	37	40	26	10	M20×1.5	M10	19.5	1/2"	10	7	12	110	89	25	22	4	55
125	279	119	160	60	74	45	46	54	41	13.5	M27×2	M12	23	1/2"	11	12	11	134	110	32	27	4	60

(Values in mm, exception O = inch)

Components and materials

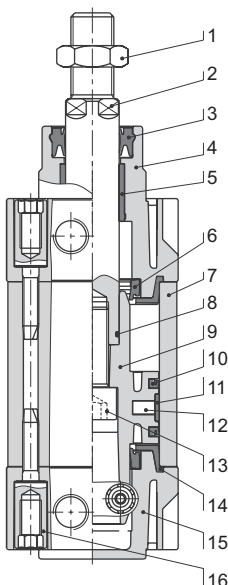

No.	Item	Material
1	Rod nut	Carbon steel ¹⁾
2	Piston rod	Carbon steel hard chrome plated ¹⁾
3	Piston rod sealing	TPU
4	Front cover	Aluminum alloy
5	Bushing	Wear resistant material (bronze)
6	Cushion O-ring	TPU
7	Barrel	Aluminum alloy
8	O-ring	NBR
9	Piston	Aluminum alloy
10	Piston O-ring	TPU
11	Wear ring	Wear resistant material
12	Magnet	Plastic / Rubber (Ø 125 mm)
13	Bolt	Carbon steel
14	Buffer gasket	TPU
15	Back cover	Aluminum alloy
16	Screw	Carbon steel ¹⁾

¹⁾ Stainless steel on request

Accessories

Male hinge model, »CA« type 437.130–437.136

(Can be combined with female hinge model, »CB« type)

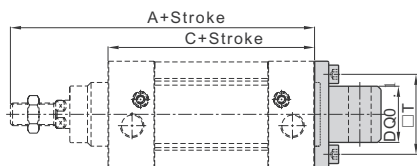
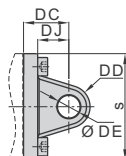

Dimensions and material

Art. No.	Piston-Ø	A	C	S	T	DC	DD	DE	DJ	DQ	Material
437.130	32	142	94	46.5	32.5	22	10.5	10	13	25.8	Nodular cast iron
437.131	40	159	105	54	38	25	12	12	16	27.8	
437.132	50	175	106	64	46.5	27	12	12	17	31.7	
437.133	63	190	121	75	56.5	32	15	16	22	39.7	
437.134	80	214	128	93	72	36	15.5	16	22	49.7	
437.135	100	229	138	110	89	41	20	20	27	59.7	Cast steel
437.136	125	279	160	134	110	50	24	25	33	69.7	

(Values in mm)

Foot model, »LB« type 437.100–437.106

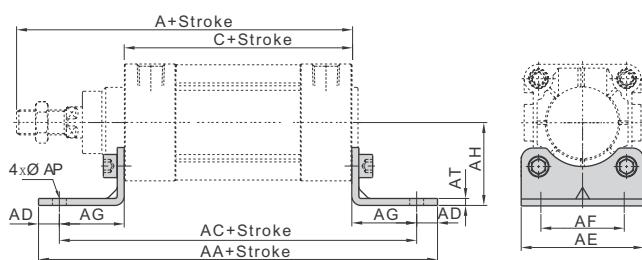

Dimensions and material

Art. No.	Piston-Ø	A	C	AA	AC	AD	AE	AF	AG	AH	AP	AT	Material
437.100	32	142	94	158	142	8	47	32	24	32	7	3	Low carbon steel
437.101	40	159	105	179	161	9	53	36	28	36	9	3	
437.102	50	175	106	190	170	10	65	45	32	45	9	3	
437.103	63	190	121	209	185	12	75	50	32	50	9	3	
437.104	80	214	128	248	210	19	95	63	41	63	12.5	4	
437.105	100	229	138	266	228	19	115	75	45	71	14.5	4	Cast steel
437.106	125	279	160	290	250	20	140	90	45	90	16.5	8	

(Values in mm)

Accessories

Flange model, »FA« type 437.140–437.146

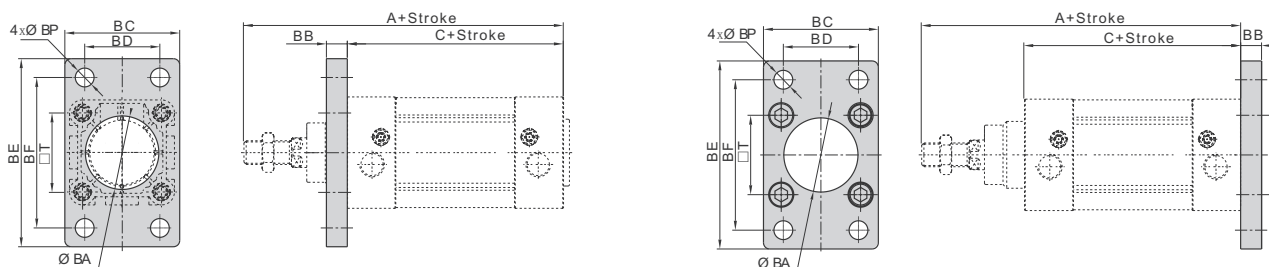

Dimensions and material

Art. No.	Piston-∅	A	C	BA	BB	BC	BD	BE	BF	BP	T	Material
437.140	32	142	94	30.5	10	47	32	80	64	7	32.5	Aluminum alloy
437.141	40	159	105	35.5	10	53	36	90	72	9	38	
437.142	50	175	106	40.5	12	65	45	108	90	9	46.5	
437.143	63	190	121	45.5	12	75	50	118	100	9	56.5	
437.144	80	214	128	45.5	16	95	63	150	126	12.5	72	
437.145	100	229	138	55.5	16	115	75	176	150	14.5	89	Cast steel
437.146	125	279	160	60.5	20	139	90	218	180	16.5	110	
437.148	200	347	180	72.5	25	220	135	320	270	270	175	

(Values in mm)

Hinge bracket model, »TF« type 437.110–437.113

(Only in conjunction with hinge head model, »FTC« type)

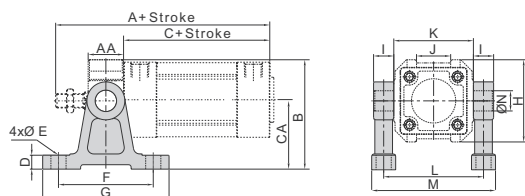

Dimensions and material

Art. No.	Piston-∅	A	AA	B	C	CA	D	E	F	G	H	I	J	K	L	M	N	Material
437.110	32	142	19	66	94	40	11	9	60	80	52	12	20	50	62	77	12	Cast steel
437.111	40	159	21	86.5	105	54	11	12	75	100	65	16	27	63	79	98	16	
	50	175	26	91.5	106	54	11	12	75	100	75	16	31	75	91	110	16	
437.112	63	190	28	115	121	70	11	12	85	110	90	20	42	90	110	133	20	
	80	214	31	126	128	70	11	12	85	110	112	20	54	110	130	153	20	
437.113	100	229	35	157.5	138	90	19	18	115	155	135	25	68	135	157	185	25	
	125	279	43	169.3	160	90	19	18	115	155	170	25	80	160	185	213	25	

(Values in mm)

Accessories

Hinge model, »TM« type 437.180–437.186

(Only in conjunction with hinge head model, »FTC« type)

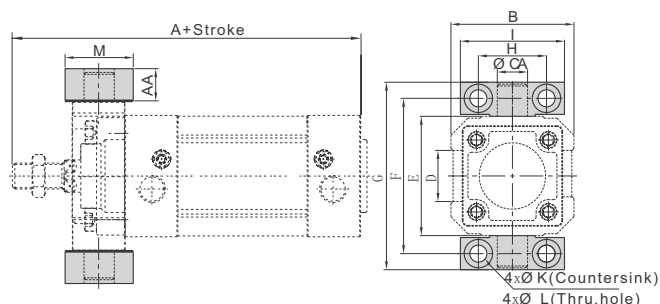

Dimensions and material

Art. No.	Piston-Ø	A	AA	B	CA	D	E	F	G	H	I	K	L	M	Material
437.180	32	142	14	52	12	20	50	66	80	32	46	11	7	30	Aluminum alloy
437.181	40–50	159	17	65	16	27	63	82	99	36	55	15	9	36	
437.183	63–80	190	20.5	90	20	42	90	113.5	134	42	65	18	11	40	
437.185	100–125	229	24.5	135	25	68	132	159.5	184	50	75	20	14	50	Cast steel

(Values in mm)

Hinge head model, »FTC« type 437.170–437.176

(Can be combined with hinge model, »TM« type or hinge bracket model, »TF« type)

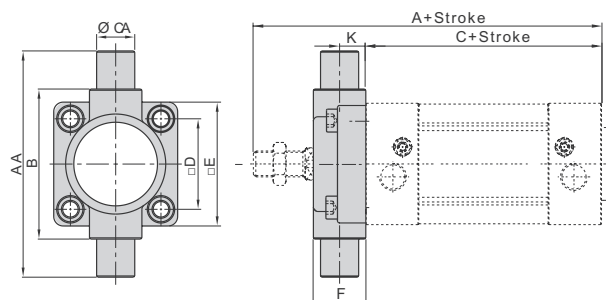
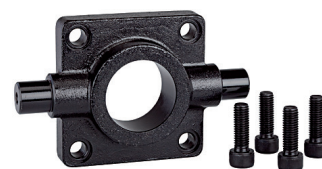

Dimensions and material

Art. No.	Piston-Ø	A	AA	B	C	CA	D	E	F	K	Material
437.170	32	142	74	50	94	12	32.5	46	19	10	Cast steel
437.171	40	159	95	63	105	16	38	52	21	10	
437.172	50	175	107	75	106	16	46.5	64	26	12	
437.173	63	190	130	90	121	20	56.5	74	28	12	
437.174	80	214	150	110	128	20	72	94	31	16	
437.175	100	229	182	132	138	25	89	114	35	16	
437.176	125	279	210	160	160	25	110	139	43	20	

(Values in mm)

Accessories

Female hinge model, »CB« type 437.150–437.156

(Can be combined with male hinge model, »CA« type)

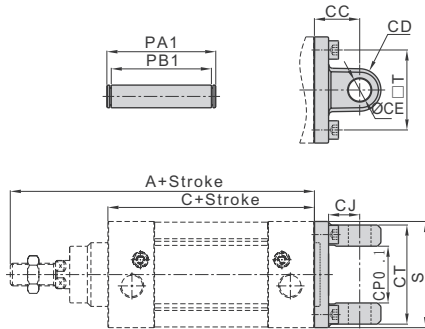

Dimensions and material

Art. No.	Piston-Ø	A	C	CC	CD	CE	CJ	CP	CT	PA1	PB1	S	T	Material
437.150	32	142	94	22	10.5	10	13	26	45	51	45.5	46.5	32.5	Nodular cast iron
437.151	40	159	105	25	12	12	16	28	52	59	52.5	54	38	
437.152	50	175	106	27	12	12	17	32	60	67	60.5	64	46.5	
437.153	63	190	121	32	15	16	22	40	70	77	70.5	75	56.5	
437.154	80	214	128	36	15.5	16	22	50	90	97	90.5	93	72	
437.155	100	229	138	41	20	20	27	60	110	119	110.5	110	89	Cast steel
437.156	125	279	160	50	24	25	33	70	130	139	130.5	134	110	

(Values in mm)

Counter-hinge model, »CR« type 437.120–437.126

(Only in conjunction with female hinge, »CB« type)

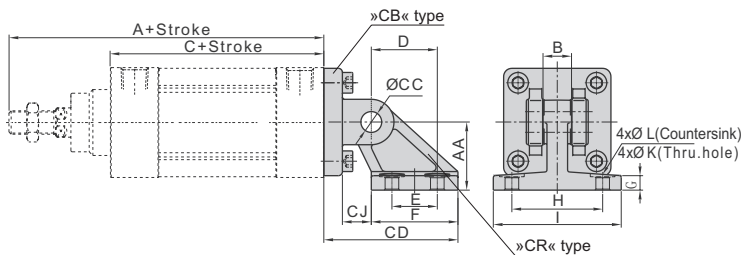

Dimensions and material

Art. No.	Piston-Ø	A	AA	B	C	CC	CD	CJ	D	E	F	G	H	I	K	L	Material
437.120	32	142	32	26	94	10	50	10	21	18	31	8	38	51	6.6	-	Nodular cast iron
437.121	40	159	36	28	105	12	56	12	24	22	35	10	41	54	6.6	-	
437.122	50	175	45	32	106	12	68	13	33	30	45	12	50	65	9	-	
437.123	63	190	50	40	121	16	77	17	37	35	50	12	52	67	9	-	
437.124	80	214	63	50	128	16	93	19	47	40	60	14	66	86	11	18	
437.125	100	229	71	60	138	20	106	22	55	50	70	15	76	96	11	18	Cast steel
437.126	125	279	90	70	160	25	135	26	70	60	90	20	94	124	14	20	

(Values in mm)

Accessories

Fork model, »Y« type 437.210–437.214

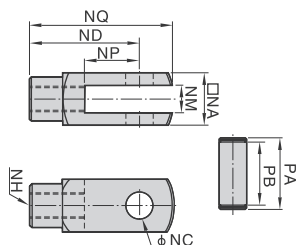

Dimensions and material

Art. No.	Piston-Ø	NA	NC	ND	NP	NQ	NM	NH	PA	PB	Material
437.313	25/32	19	10	40	20	52	10	M10x1.25	-	-	Carbon steel
437.211	40	25.4	12	48	24	62	12	M12x1.25	32.4	26.2	
437.212	50/63	32	16	64	32	80	16	M16x1.5	39	33	
437.213	80/100	44.4	20	80	40	102	20	M20x1.5	53.4	45	
437.214	125	54	30	110	55	139	30	M27x2.0	64.2	55	

(Values in mm)

Rod eye model, »UNIT« type 437.220–437.224

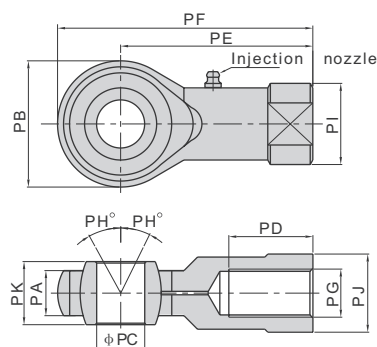

Dimensions and material

Art. No.	Piston-Ø	PA	PB	PC(H9)	PD	PE	PF	PG	PH	PI	PJ	PK	Material
437.220	32	11	26	10	20	43	56	M10x1.25	13	19	17	14	Carbon steel
437.221	40	12	32	12	22	50	66	M12x1.25	13	22	19	16	
437.222	50/63	15	40	16	28	64	84	M16x1.5	15	27	22	21	
437.223	80/100	18	46	20	33	77	100	M20x1.5	15	34	30	25	
437.224	125	25	70	30	51	111	146	M27x2.0	15	50	41	37	

(Values in mm)

Accessories

Sensors, »CS1« type 235.200–235.205

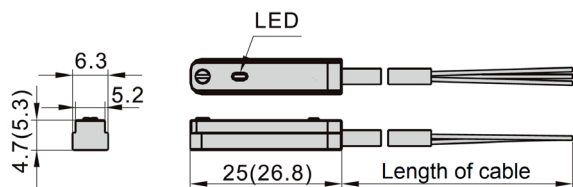

Dimensions in brackets apply to REED.

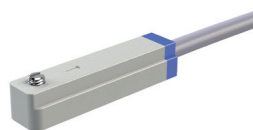

REED

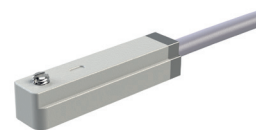

HALL

Specifications

	REED, NO	HALL, NO, NPN	HALL, NO, PNP
Operating voltage	5...240 V AC/DC		5...30 V DC
Max. switching current	100 mA		30 V / 200 mA
Max. switching rating	10 W		6 W
Max. current consumption	-		5 mA
Max. voltage drop	2.5 V at 100 mA DC		0.7 V
Max. leakage current	-		0.01 mA
Max. frequency	200 Hz		1000 Hz
Shock resistance		50 g	
Protection circuit	-	reverse polarity protected, overvoltage protection	
Temperature range	-10 °C to 70 °C*	-10 °C to 70 °C	
Enclosure classification	IP 64	IP 64**	

* High temperature version (max. 125 °C) available on request

** IP 68 available on request; only for versions with open cable.

Ordering information

Art. No.	Type No.	
115533 *	235.200	Reed sensor, 2-wire, with M8 plug, with 150 mm cable length, NO
115534	235.201	Reed sensor, 2-wire, with 3 m cable length, NO
115535	235.202	Hall sensor, 3-wire, with M8 plug, with 0.5 m cable length, NO, NPN
115536	235.203	Hall sensor, 3-wire, with 3 m cable length, NO, NPN
115537	235.204	Hall sensor, 3-wire, with M8 plug, with 0.5 m cable length, NO, PNP
115538	235.205	Hall sensor, 3-wire, with 3 m cable length, NO, PNP

*Art. No. 115533 (Type No. 235.200) is a discontinued article. Available while stocks last.

Replacement Art. No. 116944 (Type No. 235.200-1). This can be found on the following page 10.

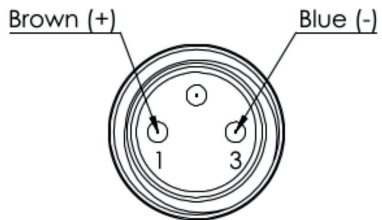
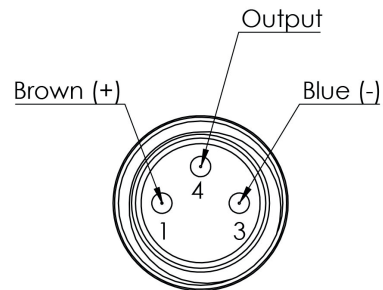
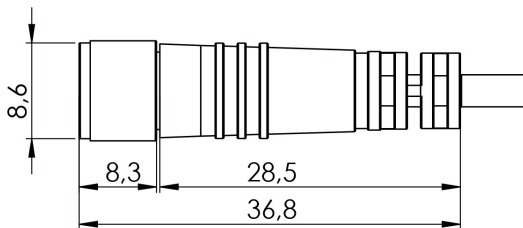
PIN assignment**M8 plug (2-wire sensor)****M8 plug (3-wire sensor)****Dimensions plug**

Ordering information

Art. No.	Type No.	Description
116944	235.200-1	Reed sensor, 2-wire, M8 plug, with 0.5 m cable length, NO

PIN assignment

M8 plug (2-wire sensor)

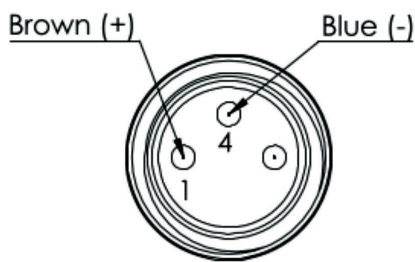

Dimensions plug

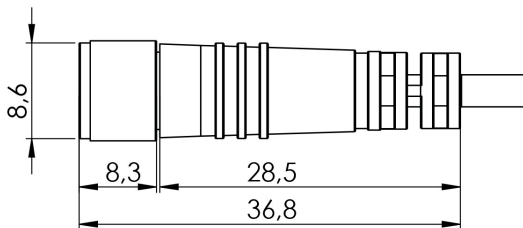

Mounting

No installation accessories are necessary for the sensor switch (235.200-235.205). It can be directly fixed in the groove of the cylinder barrel which is convenient and fast.

1. Adjust the clamping screw on sensor switch to the parallel position that enables the sensor switch to enter the installation slot.
2. Then lead the sensor switch to the installation slot and adjust it to the proper position.
3. Tighten the clamping screw to fix.

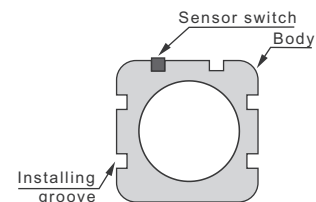

Ordering information

Art. No.	Type No.
10.DMD.32025	114636
10.DMD.32050	114637
10.DMD.32075	114638
10.DMD.32080	114639
10.DMD.32100	114640
10.DMD.32125	114641
10.DMD.32150	114642
10.DMD.32160	114643
10.DMD.32175	114644
10.DMD.32200	114645
10.DMD.32250	114646
10.DMD.32300	114647
10.DMD.32350	114648
10.DMD.32400	114649
10.DMD.32450	114650
10.DMD.32500	114651
10.DMD.40025	114652
10.DMD.40050	114653
10.DMD.40075	114654
10.DMD.40080	114655
10.DMD.40100	114656
10.DMD.40125	114657
10.DMD.40150	114658
10.DMD.40160	114659
10.DMD.40175	114660
10.DMD.40200	114661
10.DMD.40250	114662
10.DMD.40300	114663
10.DMD.40350	114664
10.DMD.40400	114665
10.DMD.40450	114666
10.DMD.40500	114667
10.DMD.40600	114668
10.DMD.40700	114669
10.DMD.40800	114670
10.DMD.50025	114671
10.DMD.50050	114672
10.DMD.50075	114673
10.DMD.50080	114674
10.DMD.50100	114675
10.DMD.50125	114677
10.DMD.50150	114678
10.DMD.50160	114679
10.DMD.50175	114680
10.DMD.50200	114681
10.DMD.50250	114682
10.DMD.50300	114683
10.DMD.50350	114684
10.DMD.50400	114685
10.DMD.50450	114686
10.DMD.50500	114687

Ordering information

Art. No.	Type No.
10.DMD.50600	114688
10.DMD.50700	114689
10.DMD.50800	114690
10.DMD.50900	114691
10.DMD.501000	114676
10.DMD.63025	114692
10.DMD.63050	114693
10.DMD.63075	114694
10.DMD.63080	114695
10.DMD.63100	114696
10.DMD.63125	114698
10.DMD.63150	114699
10.DMD.63160	114700
10.DMD.63175	114701
10.DMD.63200	114702
10.DMD.63250	114703
10.DMD.63300	114704
10.DMD.63350	114705
10.DMD.63400	114706
10.DMD.63450	114707
10.DMD.63500	114708
10.DMD.63600	114709
10.DMD.63700	114710
10.DMD.63800	114711
10.DMD.63900	114712
10.DMD.631000	114697
10.DMD.80025	114713
10.DMD.80050	114714
10.DMD.80075	114715
10.DMD.80080	114716
10.DMD.80100	114717
10.DMD.80125	114719
10.DMD.80150	114720
10.DMD.80160	114721
10.DMD.80175	114722
10.DMD.80200	114723
10.DMD.80250	114724
10.DMD.80300	114725
10.DMD.80350	114726
10.DMD.80400	114727
10.DMD.80450	114728
10.DMD.80500	114729
10.DMD.80600	114730
10.DMD.80700	114731
10.DMD.80800	114732
10.DMD.80900	114733
10.DMD.801000	114718
10.DMD.100025	114596
10.DMD.100050	114597
10.DMD.100075	114598
10.DMD.100080	114599

Ordering information

Art. No.	Type No.
10.DMD.100100	114600
10.DMD.100125	114601
10.DMD.100150	114602
10.DMD.100160	114603
10.DMD.100175	114604
10.DMD.100200	114605
10.DMD.100250	114606
10.DMD.100300	114607
10.DMD.100350	114608
10.DMD.100400	114609
10.DMD.100450	114610
10.DMD.100500	114611
10.DMD.100600	114612
10.DMD.100700	114613
10.DMD.100800	114614
10.DMD.100900	114615
10.DMD.125025	114616
10.DMD.125050	114617
10.DMD.125075	114618
10.DMD.125080	114619
10.DMD.125100	114620
10.DMD.125125	114621
10.DMD.125150	114622
10.DMD.125160	114623
10.DMD.125175	114624
10.DMD.125200	114625
10.DMD.125250	114626
10.DMD.125300	114627
10.DMD.125350	114628
10.DMD.125400	114629
10.DMD.125450	114630
10.DMD.125500	114631
10.DMD.125600	114632
10.DMD.125700	114633
10.DMD.125800	114634
10.DMD.125900	114635

Ordering information

Art. No.	Type No.
437.100	115751
437.101	115752
437.102	115753
437.103	115754
437.104	115755
437.105	115756
437.106	115757
437.110	115760
437.111	115761
437.112	115762
437.113	115763
437.120	115764
437.121	115765
437.122	115766
437.123	115767
437.124	115768
437.125	115769
437.126	115770
437.170	115793
437.171	115794
437.172	115795
437.173	115796
437.174	115797
437.175	115798
437.176	115799
437.180	115800
437.181	115801
437.183	115802
437.185	115803
437.150	115786
437.151	115787
437.152	115788
437.153	115789
437.154	115790
437.155	115791
437.156	115792
437.130	115772
437.131	115773
437.132	115774
437.133	115775
437.134	115776
437.135	115777
437.136	115778

Ordering information

Art. No.	Type No.
437.140	115779
437.141	115780
437.142	115781
437.143	115782
437.144	115783
437.145	115784
437.146	115785
437.313	115835
437.211	115810
437.212	115811
437.213	115812
437.214	115813
437.220	115814
437.221	115815
437.222	115816
437.223	115817
437.224	115818
235.200	115533
235.201	115534
235.202	115535
235.203	115536
235.204	115537
235.205	115538