



## Pressure reducer for drinking water

**100.21 to 100.26**
**R 1/2 to R 2**
**Low-pressure type  
0.5 to 2 bar**

### Characteristics

Order No.	100.21	100.22	100.23
Thread	R 1/2	R 3/4	R 1
Order No.	100.24	100.25	100.26
Thread	R 1 1/4	R 1 1/2	R 2
Pressure gauge port	G 1/4		
Type of construction	<b>Diaphragm pressure regulator with pressure-reduced single-seated valve</b>		
Medium	Water, non-corrosive liquids Compressed air, nitrogen		
Control range p <sub>2</sub>	0.5 to 2 bar		
Mounting position	<b>Horizontal, strainer cup at bottom</b> <b>Please heed the installation instructions contained in the installation and operating manual</b>		
Max. input pressure p <sub>1</sub>	25 bar, brass strainer cup		
Mounting type	Horizontal in-line		
Operating temperature	2 to 70 °C		
Min. pressure drop Δp	0.5 bar		

### Materials

Part	Material
Body	Brass
Intermediate ring	Brass
Screw fittings	Brass
Valve insert	High-quality plastic
Fine screen	Stainless steel
Spring bonnet with adjusting knob	High-quality plastic
Strainer cup	Brass
Diaphragm	NBR, braided
Seals	NBR
Adjustment spring	Spring steel

### Description

- Pressure gauge port on both sides: G 1/4
- Adjusting knob for the outlet pressure
- Screw fittings and pressure gauge Ø63 included
- Valve insert made of high-quality plastic, replacement without dismantling
- Integrated fine screen, mesh size 0.16 mm
- Brass strainer cup
- Independent of inlet pressure, inlet pressure variations have no influence on the outlet pressure
- No contact between the adjustment spring and the drinking water
- No need to remove the pressure reducer from the pipe for maintenance and repair
- Meets German KTW specifications
- Lightweight design
- Converts easily to a back-flushing filter combination
- Can be retrofitted with an upstream non-return valve
- Reliable and proven

### Applications

The pressure reducers in the 100... series protect domestic water installations against high supply pressure. They can also be used for commercial or industrial purposes providing their specification is adequate.

Using a pressure reducer prevents pressure damage and reduces water consumption. The set pressure remains constant, even if the inlet pressures vary significantly. By reducing the operating pressure and maintaining it at a constant level, it is possible to keep undesirable flow noises in the installation to a minimum.

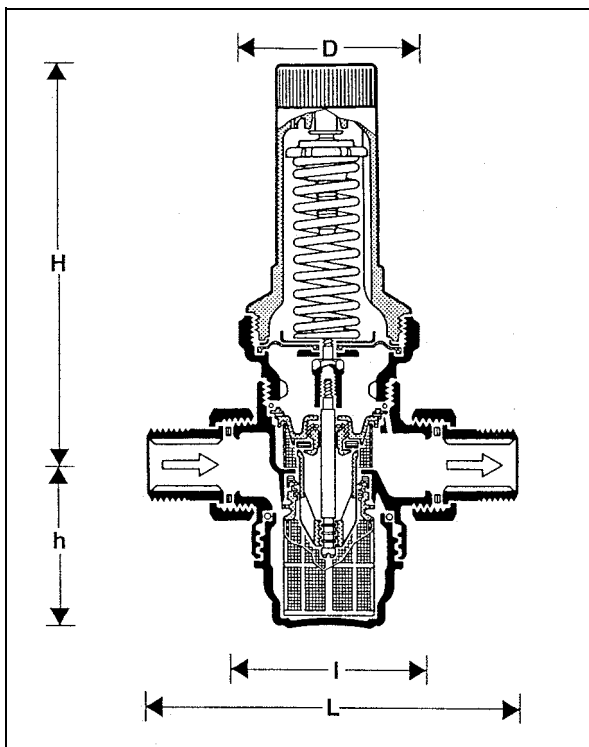
**Dimensions [mm]**

**Installation**

- The pressure reducer should preferably be installed in a horizontal pipe with the strainer cup at the bottom
  - This mounting position facilitates cleaning
- Shut-off valves must be provided
  - Shut-off valves allow the pressure reducer to be maintained and repaired without being removed from the pipe
- Ensure easy accessibility
  - The pressure gauge must be clearly visible
  - Maintenance and inspection are simplified
- Install downstream of the fine filter
  - The pressure reducer is optimally protected against dirt
- A settling section equivalent to at least 5 x DN is recommended downstream of the pressure reducer (DIN 1988, Part 5)

**Minimum clearance between wall and centre of pipe**

Thread	R	1/2	3/4	1	1¼	1½	2
	[mm]	55	55	60	60	70	70

Thread	R	1/2	3/4	1	1¼	1½	2
Nominal diameter	DN	15	20	25	32	40	50
Weight	approx. [g]	1400	1600	2400	2800	4400	5600
Dimensions	[mm]						
	L	140	160	180	200	225	255
	I	80	90	100	105	130	140
	H	148	148	185	185	210	210
	h	56	56	77	77	113	113
	D	73	73	83	83	102	102
Kvs value		2.4	3.1	7.6	9.1	12.6	12.0
Peak flow, water (m³/h)							
acc. to DIN 1988, Part 5							
Residential buildings		1.8	2.9	4.7	7.2	8.3	13
Commercial buildings		1.8	3.3	5.4	8.6	13.7	21.2

**Main spare parts**

Thread	Part				
	Valve re- placement kit	Replace- ment strainer	Strainer cup		Pressure gauge
			Transparent	Brass	
R ½ + R ¾	100/211	100/221		100/261	215-
R 1 + R1¼	100/212	100/222	--	100/262	
R 1½ + R 2	100/213	100/223		100/263	

**Flow rates**

Water	Air
Kvs x $\sqrt{p_1-p_2}$	See nomogram Page <b>2-26</b>

**Maintenance**

	Activity	Interval	Responsible
<b>Inspection</b>	Visual inspection of the output pressure setting on the pressure gauge at zero and peak flow (high draw-off quantity)	Once every year	Owner or plumbing firm
<b>Maint- enance</b>	Clean the screen and if necessary replace  If the output pressure setting does not yield a constant value at zero flow, the valve insert must be removed, inspected and if necessary replaced	Once every 1 to 3 years, depending on local operating conditions	Plumbing firm

**Accessories**

Designation	Order No.
Double ring spanner - For threads R 1/2 to R 1 R 1¼ to R 2	ZR 06 B ZR 06 A
Wearing part set consisting of: 2x cap nuts, 2x screw fittings, 2x sealing rings	See chart



ZR 06 A

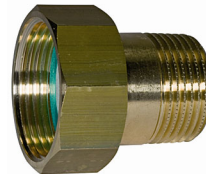

VST06-1A

Order No.	a/f	Seal outside Ø	Length	Thread
VST06-1/2A	30 mm	24 mm	28 mm	1/2"
VST06-3/4A	37 mm	30 mm	32 mm	3/4"
VST06-1A	46 mm	38,5 mm	38 mm	1"